

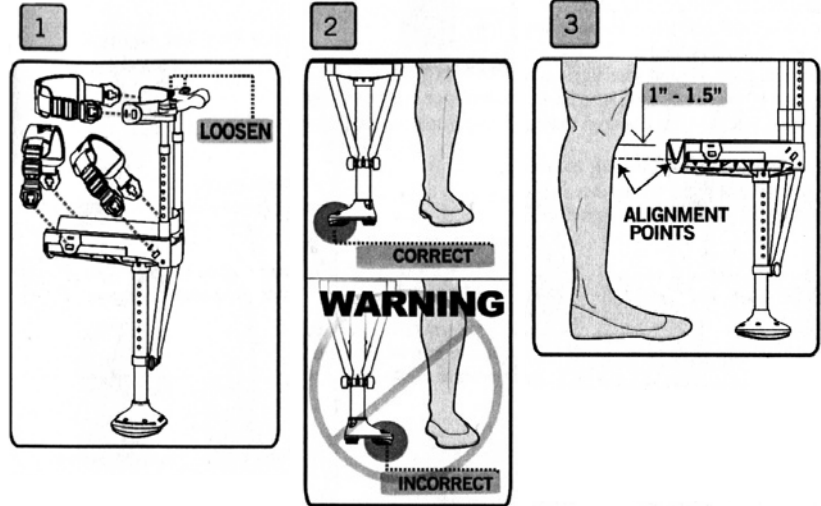

- 1.) Remove the 3 Straps; Loosen the Thumb Screws so that Thigh Supports can rotate freely.
- 2.) Position the Foot for left or right leg use by pressing in the adjustment spring heads and rotating the Foot into position.
- 3.) Adjust the height of the lower crutch by aligning the bottom of the "v" at the back of the Knee Platform with a point 1-1.5" below the bottom of your knee-cap. Make sure the adjustment spring heads are FULLY ENGAGED, then tighten the Clamp Nut and Bolt.



Note: The Knee Platform is intentionally positioned slightly lower than optimum. Later, you will raise it to full height. Grasp the Handle and carefully kneel on the crutch. At this point DO NOT rely on the crutch for balance or support! With feet side by side and shoulder width apart, you should have a slight bend in your good knee.

Important: Both adjustment spring heads must be fully engaged in the adjustment holes before putting weight on the crutch. Failure to do so could result in a fall and injury.

- 4.) Position the Thigh Supports as high as possible on your leg by pulling up or pushing down on the Handle while pressing the adjustment spring button.
- 5.) Tilt the crutch slightly inward by pushing the handle toward your body center line until both Foot Treads are contacting the ground.

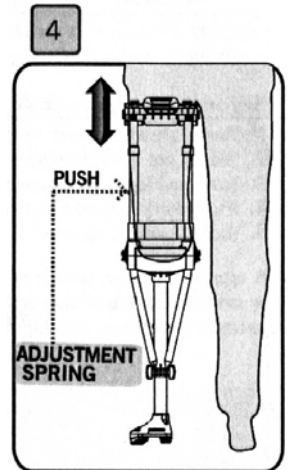

Next, rotate the inner Thigh Support until it's firmly against your inner thigh. Firmly tighten the Thumb Screw to lock in this position, then repeat this step on the other side. It's not uncommon for the inner Thigh Support to be rotated further in than the outer Thigh Support. Make sure that the interconnecting teeth of the Thigh Supports and Handle are fully engaged and the Thumb Screws are firmly tightened.

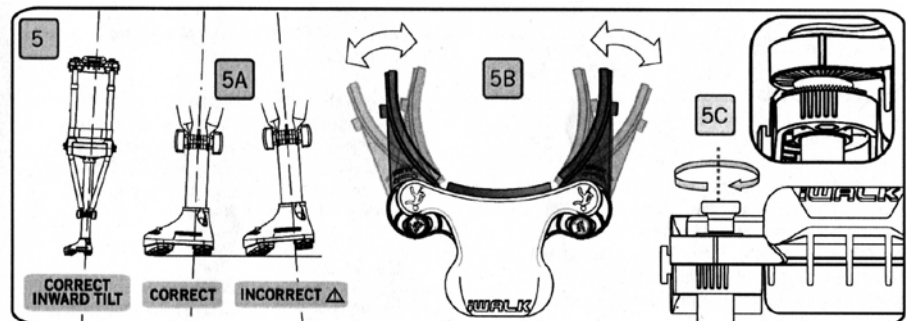

(Continued on back)

6.) The Straps are composed of 2 sections. The side with the Black buckles is for length adjustment. The side with the Gray buckles is for final

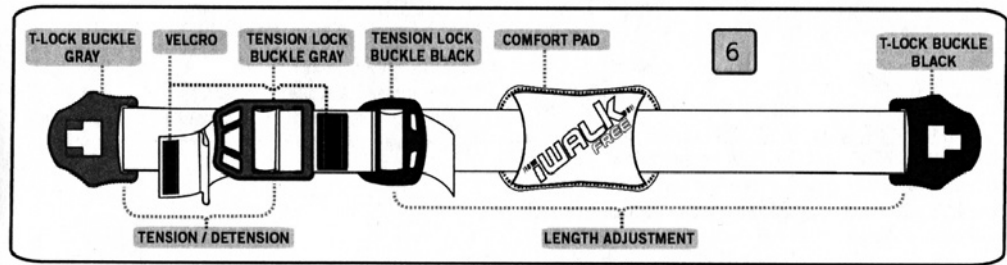

tensioning only (to put on and take off the crutch). Fully extend both sections of the Strap by lifting on the lip of the Tension Lock Buckles while pulling out on the T Lock Buckles. Repeat for all 3.

7.) Install the 3 Straps onto the Crutch. Install the Black T Lock Buckles on the inner leg side of the crutch.

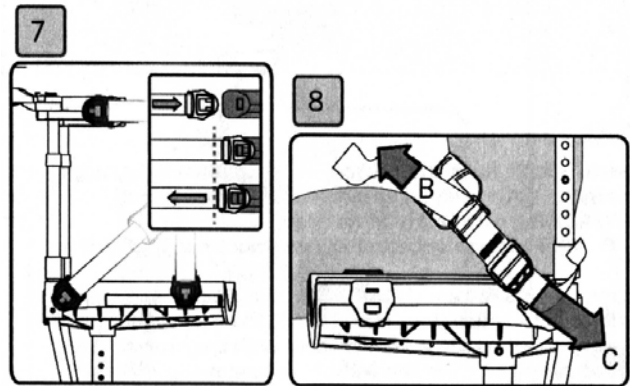

8.) Holding the Handle, kneel on the crutch. Drape the Strap over the back of your knee and install the Gray T Lock Buckle onto the Knee Platform.

9.) Position your knee at the front of the Knee Platform and pull on the end of the Adjustment side of the Strap until it's snug (but not fully tightened).

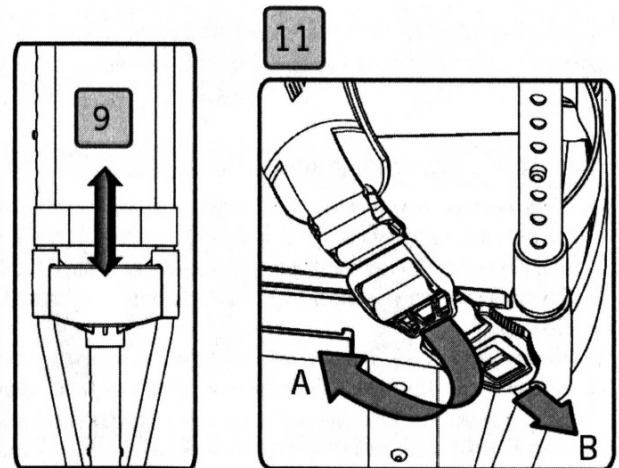

Cinch down the strap by pulling down on the Tension end of the strap. If tensioned properly, it should be difficult to push a finger between the strap and your leg. When finished, secure the strap end by connecting the Velcro tab at the end of the strap to the Velcro strip between the Black and Gray buckles. Repeat for the other two Straps. Slide the Knee Strap up or down so that it's tight against your lower thigh.

10.) (NO IMAGE) Slide the Comfort Pads so that they are centered on the back of your legs. You can tuck any excess Adjustment Strap underneath the logo section of the Pad.

11.) To remove the crutch, lessen the tension of the strap by lifting the lip of the Gray Tension Lock buckle. Once tension is relieved, remove the Gray T Lock buckle. Repeat for the other two Straps.

A Leg Up
OF MINNESOTA

